

Procedure for Rivet Bonding with LORD Fusor[®] Adhesives

Materials Needed:

- LORD Fusor 108B/109B Metal Bonding Adhesive (Medium) or LORD Fusor 112B/113B Metal Bonding Adhesive (Slow)
- LORD Fusor 123/126 Non-Sag Seam Sealer (Fast), or LORD Fusor 129 Controlled Flow Seam Sealer (Fast), or LORD Fusor 123EZ/126EZ Non-Sag Seam Sealer (Medium), or LORD Fusor 800EZ/801EZ/803EZ Factory Match Urethane Sealer/Adhesive
- LORD Fusor 300 or 301 Manual Dispensing Gun, or LORD Fusor 304 or 304X Pneumatic Dispensing Gun

Rivet bonding is defined as a method of joining metals which involves the installation of structural rivets used in conjunction/combination with a structural adhesive.

Today's automotive metals are becoming increasingly more complex as the OEMs are progressively utilizing many different materials in the construction of automobiles and trucks to promote safety, eliminate excessive vehicle weight and allow for better styling. Some metals including aluminum, laminated steel and advanced high strength steels may be difficult, if not impossible to weld using conventional welding techniques. Therefore, rivet bonding has become a recognized method for joining similar and dissimilar metals.

Although LORD Fusor[®] Automotive Repair Systems recommends fully bonded secondary, non-structural panels, there are cases where an OEM may recommend a rivet and adhesive bonding operation. This repair procedure is designed to be used as a guideline for rivet bonding repairs or replacements of secondary, non-structural or structural body panels and/or patch panels as necessary. Please consult the particular automobile manufacturer's body repair manual or technical service bulletin for vehicle specific repair information.

LORD Fusor 108B/109B metal bonding adhesive is specified by General Motors as the structural adhesive for rivet bonding laminated steel.

LORD Fusor 108B/109B and 112B/113B metal bonding adhesives are recommended to use for rivet bonding structural and non-structural body panels, depending on temperature and work time needed. For this repair procedure, LORD Fusor 108B/109B metal bonding adhesive will be used.

Surface Preparation

1. Straighten the uni-body on a frame machine to manufacturer's specifications.
2. Once the damaged vehicle has been straightened, remove the damaged panels with an air saw or air chisel. Remove only the large portions, making sure not to cut into the mating flanges or adjacent parts.
3. Using a spot-weld cutter, drill out the spot welds and remove the remaining weld flanges of the panel to be replaced. If rivets were previously used, drill out or grind the rivets to remove.
4. Pay special attention to preparing any damaged flanges on the vehicle. Straighten these flanges using a hammer and a dolly.
5. Grind the mating surface of the original flanges (not greater than 1 inch [25.4 mm]), being sure to remove any adhesive, e-coating, corrosion protection or galvanized coating. If the metal has a pewter appearance, then all of the galvanized coating has not been removed. The metal should be shiny in appearance. Be careful not to damage the corners or thin the metal.
6. Carefully grind the entire outer edges of the new panel to which LORD Fusor metal bonding adhesive (Stock #108B/109B) will be applied, making sure to remove any e-coat, paint or galvanized coating as described in Step #5.

7. Ensure that the vehicle is evenly supported at normal suspension points.
8. Pre-fit all parts to ensure proper alignment.
9. Drill holes for rivets in both panels to accommodate the size of the structural rivets.

Adhesive Preparation

1. Insert the LORD Fusor metal bonding adhesive cartridge (Stock #108B/109B) into the appropriate dispensing gun. Squeeze a small amount of product from each side of the cartridge to level the plungers.
2. Attach a mixing tip and dispense a small amount of adhesive, which is about the length and width of the mixer. Dispense until the product is evenly mixed and the color is consistent.

Note: From this point you will have about 40-50 minutes at 70°F (21°C) (approximately 70 minutes with LORD Fusor 112B/113B metal bonding adhesive) to apply the adhesive and assemble the components.

Panel Installation

1. Apply a 3/8 to 1/2 inch (9.5 to 12.7 mm) bead of LORD Fusor metal bonding adhesive to the bare metal mating surfaces (**see Illustration A**).
2. Properly position the new panel. Once the panel has been positioned, do not pull it away from the vehicle. If repositioning is necessary, slide the panel. This maintains proper contact between the two panels.
3. Clamp tightly and evenly. The glass beads in the adhesive will prevent you from over clamping the bondline.
4. Install the structural rivets as previously determined by using a manual or pneumatic rivet gun. Use structural rivets as recommended by the OEM.
5. Remove clamps after all rivets have been installed.

6. Where possible, wipe excess adhesive from panel before it cures. This will save you time later.
7. Allow the adhesive to fully cure for 8 hours before painting. Expect the adhesive to be a little “tacky” on the surface as this is a normal property of the adhesive.
8. Remove all cured excess adhesive using a DA sander or angle grinder.
9. Finish sand the joint as necessary and prime the exposed metal with a 2K primer. Allow the primer to fully cure per the paint manufacturer’s recommendation.
10. Use LORD Fusor non-sag seam sealer (Stock #123/126 or #123EZ/126EZ), LORD Fusor controlled flow seam sealer (Stock #129) or LORD Fusor factory match urethane sealer/adhesive (Stock #800EZ/801EZ/803EZ) wherever a cosmetic seam sealer is required.
11. Prime and paint per the paint manufacturer’s recommendations.

Illustration A

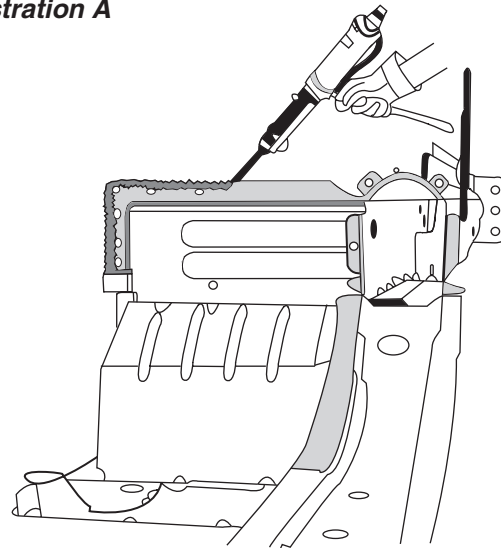

Fusor and “Ask Us How” are trademarks of LORD Corporation or one of its subsidiaries.

LORD provides valuable expertise in adhesives and coatings, vibration and motion control, and magnetically responsive technologies. Our people work in collaboration with our customers to help them increase the value of their products. Innovative and responsive in an ever-changing marketplace, we are focused on providing solutions for our customers worldwide . . . Ask Us How.

LORD Corporation World Headquarters

111 Lord Drive
Cary, NC 27511-7923
USA

Customer Support Center

+1 877 ASK LORD (275 5673)

www.lord.com